

After more than 50 years on the market, Erba is today a leader in the production and creation of bedrooms for kids and children. This dynamic company, located in the heart of Brianza - where you can find the production headquarters, as well as the offices and showrooms - makes use of cutting-edge technology and a young workforce, adjectives that perfectly describe this growing business. We continuously invest in production - one of Italy's most innovative systems - along with research and development of products that meet new styles and needs. All of this has made Erba a world-renowned company. Thanks to our hard work, our production unit can now take advantage of high-tech machinery and systems, specifically designed by a team of experts to meet company needs. We can now offer our clients and customers the utmost flexibility and customization for their projects. These products are created for those who want an exclusive style - people who pay a great deal of attention to design - in this case, truly minimalist. Our furnishings are always contemporary, thanks to essential lines and punctilious style. This is a balanced mix of innovation, safety, dependability, and design. And these are the fundamental ingredients that give shape and colour to interiors for your kids.

Présente depuis plus de 50 ans sur le marché, Erba est aujourd'hui un des leaders les plus importants dans la production de chambres pour enfants. Elle est située au cœur de la Brianza où se trouvent l'unité de production, les bureaux et le showroom. Une entreprise dynamique, jeune et technologiquement avancée, ce sont les adjectifs les plus appropriés pour décrire une réalité en croissance constante. Un investissement continu, d'une part dans les systèmes de production, incontestablement parmi les plus innovateurs au niveau national et d'autre part dans les activités de recherche pour le développement de produits toujours actuels, ont fait d'Erba une entreprise reconnue au niveau international. Grâce aux efforts continus, l'unité productive peut utiliser aujourd'hui des installations hautement spécialisées, projetées par des équipes d'experts pour répondre en mode particulier aux exigences de l'entreprise et offrir au client final une plus grande flexibilité et une plus grande personnalisation du projet. Elle propose des produits qui s'adressent à ceux qui recherchent un style exclusif et prêtent une grande attention au design, en l'occurrence extrêmement minimaliste. Des éléments toujours contemporains grâce à leurs lignes essentielles et strictes. Un mélange équilibré d'innovation, sécurité, fiabilité et design. Ce sont précisément les ingrédients indispensables pour donner forme et couleur à l'espace dédié aux jeunes.

Nach mehr als 50 Jahren Marktpräsenz ist Erba heute einer der wichtigsten Anbieter von Einrichtung für das Kinderzimmer. Seine Produktionsstätten, Verwaltungsgebäude und der Showroom befinden sich im Herzen von Brianza, in der Region Lombardei. Es handelt sich um ein junges und dynamisches, technologisch hochqualifiziertes Unternehmen mit kontinuierlichem Wachstumstrend. Dank konstanter Investition in die Entwicklung topaktueller Produkte und in innovative Produktionssysteme, die landesweit zu den fortschrittlichsten gehören, genießt Erba internationales Ansehen. Mit hochspezialisierten Fertigungsanlagen, die von Experten speziell für die Anforderungen des Unternehmens entwickelt wurden, kann Erba dem Endkunden ein Höchstmaß an Flexibilität und Personalisierung der Projekte anbieten. Die Produktpalette richtet sich an ein Publikum mit exklusivem Stil und Sinn für Design - hier mit extremem Minimalismus interpretiert. Essenzielle, formal schlüssige Linien gewährleisten zeitgemäße Optik - ein ausgewogener Mix aus Innovation, Sicherheit, Zuverlässigkeit und Design. Und für die Raumgestaltung von Kindern und Jugendlichen sind genau diese Elemente unverzichtbar.



Dopo oltre 50 anni di presenza sul mercato, Erba è oggi uno dei maggiori leader nella produzione di camere per ragazzi. Situata nel cuore della Brianza, dove trovano sede l'unità produttiva, gli uffici e lo showroom.

Dinamica, giovane e tecnologicamente avanzata. Sono questi gli aggettivi più adatti per descrivere una realtà continuamente in crescita. Un costante investimento in sistemi di produzione, in assoluto tra i più innovativi presenti sul territorio nazionale, e in attività di ricerca, per lo sviluppo di prodotti sempre di tendenza, hanno reso Erba riconosciuta a livello internazionale.

Grazie a questo continuo impegno, l'unità produttiva gode dell'utilizzo di impianti altamente specializzati, progettati da team di esperti appositamente per soddisfare le esigenze dell'azienda che grazie a ciò offre al cliente finale massima flessibilità e massima personalizzazione del progetto.

Prodotti rivolti a coloro che ricercano uno stile esclusivo e prestano molta attenzione al design, in questo caso estremamente minimalista. Elementi sempre contemporanei grazie alle loro linee essenziali e rigorose. Un equilibrato mix di innovazione, sicurezza, affidabilità e design. Sono questi gli ingredienti indispensabili per dare forma e colore allo spazio dei giovani.



FREE
STYLE

MULTI
BOX



LETTI
1x2



Voi e Erba

Erba and you

Find us



I nostri prodotti sono distribuiti solo ed esclusivamente attraverso una rete di rivenditori autorizzati in grado di offrire un servizio di progettazione ed assistenza post-vendita. Ti invitiamo a visitare il nostro sito per conoscere il rivenditore Erba più vicino.

Our products are distributed solely and exclusively through authorized dealers who can also offer design services and after-sales assistance. Please visit our website to find out where you can find the Erba retailer nearest to you.

Nos produits sont distribués uniquement et exclusivement à travers un réseau de revendeurs autorisés en mesure d'offrir un service de projet et d'assistance après-vente. Nous vous invitons à visiter notre site pour connaître le revendeur Erba le plus proche de chez vous.

Unsere Produkte erreichen den Markt über ein exklusives Vertriebsnetz von ausgewählten Partnern, die angemessene Planungs- und Kundenbetreuungsdienste anbieten können. Bitte besuchen Sie unsere Website, um den nächsten autorisierten Vertriebspartner von Erba zu finden.

Puoi scoprire l'intera collezione Erba, i video e le foto ed essere sempre aggiornato sulle ultime novità seguendo la nostra pagina Facebook o Twitter o visitando il nostro sito. Iscrivendoti alla newsletter avrai inoltre la possibilità di ricevere i nostri aggiornamenti.

You can also look through the entire Erba collection, including videos and photographs, with all our new offers, or by following us on Facebook and Twitter. By signing up for our newsletter, you can receive all the latest news on products we offer.

Vous pouvez découvrir toute la collection Erba, les vidéos et les photos et être constamment informé sur les dernières nouveautés en consultant notre page Facebook ou sur Twitter ou en visitant notre site. En vous inscrivant à notre newsletter vous pourrez recevoir nos dernières mises à jour.

Videos, Fotos und umfassende Informationen über die gesamte Kollektion von Erba stehen auf unserer Facebook-Seite, über Twitter oder auf unserer Website zur Verfügung. Abonnieren Sie unseren Newsletter, um den neuesten Stand unserer Angebote zu erhalten.

Follow us

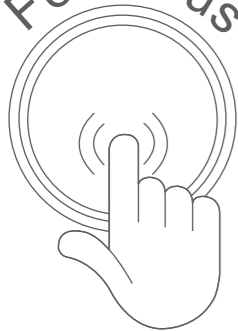

Il nostro modo per fare la differenza: largo ai colori!

Making the difference: let colours run wild!

Il nostro attuale sistema di produzione, tra i più innovativi e tecnologici al mondo, ci permette di aggiornare continuamente la gamma colori della nostra collezione e di essere sempre al passo con le ultime tendenze.

Per i nostri prodotti utilizziamo esclusivamente pannelli di melamina in classe E1, a bassa emissione di formaldeide. Scopri tutte le finiture consultando il nostro sito.

Our current production line, one of the world's most innovative and cutting-edge systems, allows us to constantly update colour choices and options for our collections, keeping up with new trends. For our products, we make exclusive use of class E1 melamine panels, with low formaldehyde emissions. Please visit our website to find out more about all of our finishes and finishing.

Notre système de production actuel, parmi les plus innovateurs et technologiques au monde, nous permet de mettre continuellement à jour la gamme de couleurs de notre collection et de suivre le nouvelles tendances. Pour nos produits nous utilisons exclusivement des panneaux de mélamine de classe E1, à basse teneur de formaldéhyde. Vous pouvez découvrir toutes les finitions en consultant notre site.

Wir verfügen über ein Produktionssystem, das weltweit zu den innovativsten und technologisch fortschrittlichsten seiner Art gehört. Dadurch können wir aktuellen Tendenzen mit einer ständig neuen Farbpalette entsprechen. Für unsere Produkte verwenden wir ausschließlich Melamin-beschichtete Platten der Klasse E1 mit niedrigen Formaldehydemissionen. Auf unserer Website stehen umfassende Informationen über die Fertigbearbeitung zur Verfügung.

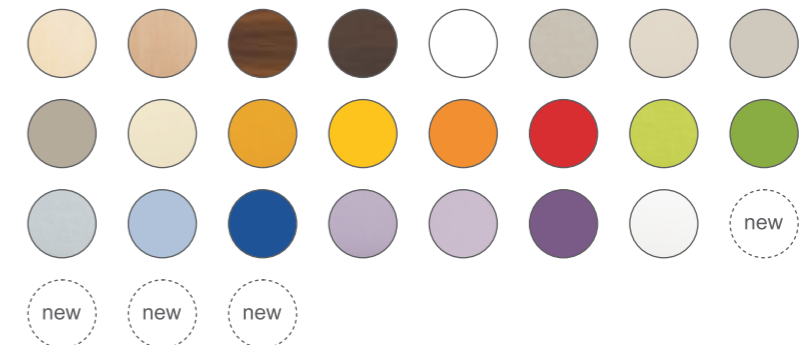
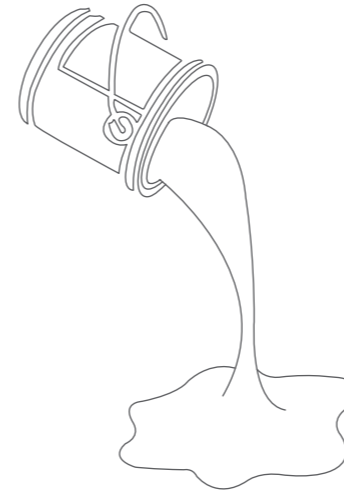



Buone ragioni per scegliere Freestyle

More great reasons to choose Freestyle

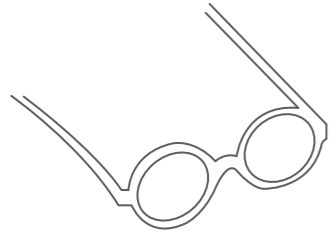

reSearch

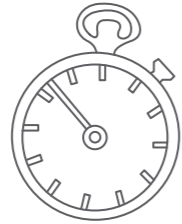

UN prodotto
Senza tempo

100%
Made IN italy



costo
accessibile

100%
quality



Le Migliori
Materie prime

deSign



idé es



INNOVATION



FLeSSibiLità

- quality
 - Service
 - reLIability
-
- SatiSFactiON

attention to
every



detail

PERSONALIZZAZIONE



teCHNOLOGY



Per maggiori dettagli visitate il nostro sito www.erbamobili.it
For further details, please visit our website www.erbamobili.it

Why should we simply call it "the kids' room"?
It's the place where parents read fairy tales over and over again,
until they know every word by heart.
Here the kids play. They watch cartoons and then movies.
They study. Sometimes.
Friends stay over, friends for adventures,
or more often, getting into trouble.
They confide, they cry, they laugh, they dream.
They grow up.
An intimate, versatile place,
which needs to be welcoming and practical for those needs,
changing every day.
This is why Freestyle was created.
Because your needs are our goals.

Pourquoi la définir simplement "chambre d'enfants"?
C'est l'espace où les parents lisent et relisent des fables
jusqu'à en connaître par cœur chaque mot.
C'est le lieu où l'on joue. Où l'on regarde des dessins animés et
ensuite des films.
C'est le lieu où l'on étudie. Parfois.
On y reçoit des amis, des compagnons d'aventure
ou plus souvent de mésaventure.
C'est le lieu où l'on se confie, on pleure, on rit, on rêve.
C'est là que l'on grandit.
Un espace intime, versatile,
qui doit savoir accueillir et répondre
aux différentes et nombreuses exigences
qui se présentent en mode récurrent chaque jour.
Freestyle est né pour cela.
Parce que vos désirs sont pour nous synonymes d'objectif.

Mehr als ein "Kinderzimmer"?
Ein Raum, wo vorgelesen wird, bis auch die Eltern jedes Wort
der Geschichte auswendig können.
Ein Raum zum Spielen.
Wo man sich erst Zeichentrick- und später Spielfilme und Dokus ansieht.
Wo Hausaufgaben erledigt werden. Jedenfalls meistens...
Wo Freunde und Spielgefährten zu Besuch kommen.
Wo man anderen das Herz ausschütten, weinen, lachen und träumen kann
Wo man wächst und weiterkommt.
Ein intimer Raum, der vielfältige Funktionen erfüllen muss, um täglich aufs
Neue die unterschiedlichsten Anforderungen zu erfüllen.
Dafür haben wir Freestyle konzipiert.
Denn die Wünsche des Kunden sind uns ein Ziel.

“ Perché definirla semplicemente “cameretta”?
È quello spazio dove i genitori leggono e rileggono
le fiabe fino a conoscerne
a memoria ogni singola parola.
Si gioca. Si guardano i cartoni animati poi i film.
Si studia. A volte.
Si ospitano gli amici, compagni di avventura,
o più spesso, disavventura.
Ci si confida, si piange, si ride, si sogna.
Si cresce.
Uno spazio intimo, versatile,
che deve saper accogliere e soddisfare
le diverse esigenze, molte,
che si presentano ricorrenti ogni giorno.
Freestyle nasce per questo.
Perché il vostro desiderio è per noi un obiettivo. ”



LA CAMERA DINAMICA: STUDIARE, DORMIRE E GIOCARE

LO SCRITTOIO SCORREVOLE
È UTILIZZABILE DA ENTRAMBI I LATI
E CONSENTE DI GESTIRE LO SPAZIO
SECONDO LE ESIGENZE
AVETE BISOGNO DI PIÙ SPAZIO?
LO SCRITTOIO SI PUÒ SOVRAPPORRE AL LETTO

The dynamic room:
study, sleep, and play
The sliding desk can be used on both
sides, allowing you to manage your space
based on your needs.
Do you need more space?
The desk can be placed over the bed

La chambre dynamique:
étudier, dormir et jouer
Le bureau coulissant peut être utilisé des
deux côtés et il permet de gérer l'espace
selon les exigences.
Vous avez besoin de plus de place?
Le bureau se superpose au lit

Das dynamische Zimmer:
schlafen, lernen und spielen
Zur bedarfsgerechten Nutzung des
Raums kann der fahrbare Schreibtisch
beidseitig verwendet werden. Es ist mehr
Platz gefragt? Dann kann der Schreibtisch
über das Bett gefahren werden







C'est la musique que j'aime / =>

demain bel des
amisants /
- 20.00 -



PER STUDIARE CI VUOLE SPAZIO

CON I MODULI DELLA COLLEZIONE MULTIBOX
CREARE LA SOLUZIONE IDEALE
È UN GIOCO DA RAGAZZI GRAZIE ALL'AMPIA
VARIETÀ DI LIBRERIE E CONTENITORI

You need room to study
With the modules of the Multibox
collection, creating the perfect solution is
simply child's play, thanks to the vast
choices of bookshelves and storage units

Pour étudier il faut de l'espace
Avec les modules de la collection
Multibox créer la solution idéale est un
jeu d'enfants grâce à la vaste variété de
bibliothèques et d'éléments

Wer viel lernt, der braucht auch Raum
Mit den vielseitigen Strukturelementen
der Multibox-Kollektion und Behältern
aller Art - lässt sich kinderleicht eine
ideale Lösung erstellen



DESIGN VERSATILE E FUNZIONALE

LA STRUTTURA PONTE
CON LIBRERIE MULTIBOX È UNA SOLUZIONE
INNOVATIVA E FLESSIBILE
PER COLORO CHE NECESSITANO
DI SFRUTTARE AL MEGLIO LO SPAZIO
NON TRASCURANDO
L'ESIGENZA DEL CONTENIMENTO

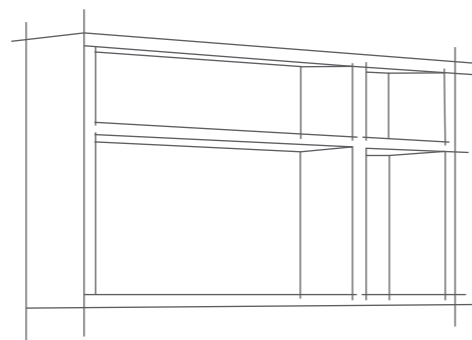

Versatile and practical design
The bridge unit with Multibox bookshelves
is an innovative and flexible solution for
those who need to take full advantage of
their interior space without leaving out
their storage needs

Design versatile et fonctionnel
La structure pont avec les bibliothèques
Multibox est une solution innovatrice et
flexible pour ceux qui ont besoin d'exploiter
au mieux l'espace sans oublier l'exigence
de rangement

Vielseitiges und funktionales Design
Die Brückenstruktur mit Multibox-
Bücherregalen ist eine innovative
Lösung für optimale Raumnutzung, ohne
den Bedarf an Aufbewahrungsbehältern
zu vernachlässigen







PROGETTARE IN LIBERTÀ

LE LIBRERIE MULTIBOX POSSONO ESSERE
SOVRAPPOSTE O SOSPENSE
È POSSIBILE CREARE INFINITE SOLUZIONI
SENZA RINUNCIARE AD UN
VERO E PROPRIO TOCCO DI DESIGN

Design freedom

The Multibox bookshelves can be stacked and suspended. You can create an infinite number of solutions, without giving up that authentic designer touch

Projeter en liberté

Les bibliothèques de la collection Multibox peuvent être superposées ou suspendues. Il est possible de créer des solutions infinies sans renoncer au design

Planung in Freiheit

Multibox-Bücherregale können übereinander aufgestellt oder aufgehängt werden. Es ist möglich, unzählige Lösungen zu erstellen, ohne auf authentisches Design zu verzichten



FUNZIONALITÀ AL PRIMO POSTO

IL LETTO INFERIORE È INDIPENDENTE
GRAZIE ALLE RUOTE
È FACILMENTE SPOSTABILE
E PUÒ ESSERE ESTRATTO
PER AGEVOLARNE
L'UTILIZZO ED IL RIFACIMENTO

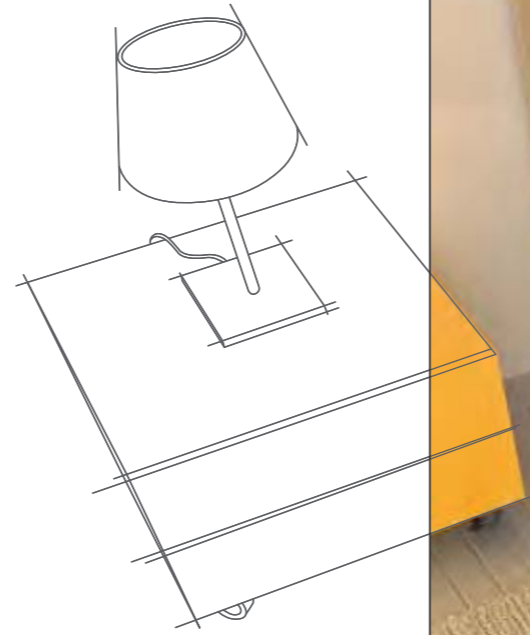

Practicality first
The lower bed is independent, and thanks to the wheels you can move it and take it out with a simple push - easy to tidy up and easy to use

Fonctionnalité à la première place
Le lit inférieur est indépendant et grâce aux roulettes il peut être facilement déplacé et extrait pour l'utiliser et le refaire facilement

Funktionalität hat Vorrang
Das untere Bett ist unabhängig und kann leicht herausgefahren werden, um einfacher verwendet oder bezogen zu werden





UNO SPAZIO PER DUE

IL LETTO 1x2 RIVOLUZIONA
IL TRADIZIONALE CONCETTO
DI LETTO A CASTELLO
DOTATO DI QUATTRO RUOTE
E DISPONIBILE FINO AD
UNA PIAZZA E MEZZA

Room for two
The 1x2 bed revolutionizes the traditional
concept of the bunk bed.
Equipped with four wheels, it is also
available in queen size

Un espace pour deux
Le lit 1x2 est une révolution dans le concept
traditionnel de lits superposés.
Doté de quatre roulettes, il est disponible
jusqu'à une place et demie

Raum für zwei
Ein 1x2 Bett revolutioniert das
herkömmliche Etagenbett. Es fährt auf
vier Rollen und steht bis zur Breite des
französischen Betts zur Verfügung





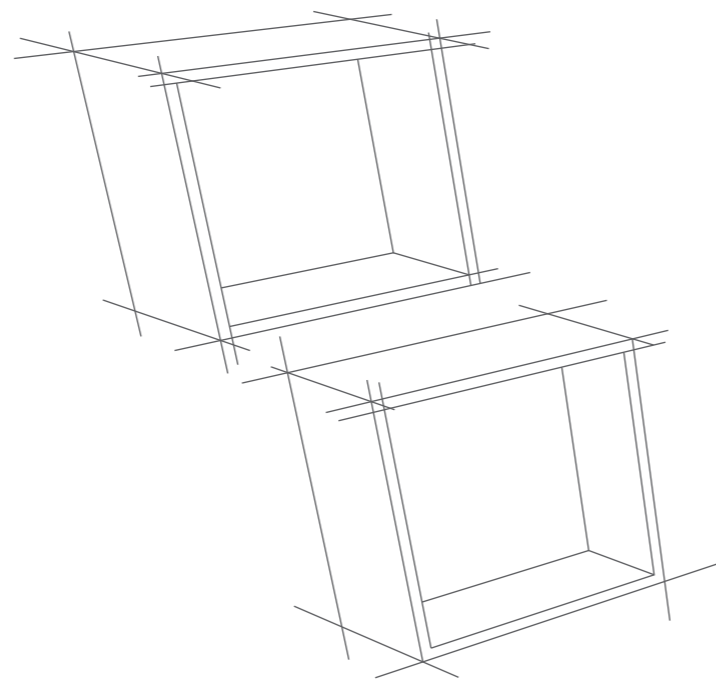

LO SPAZIO È PREZIOSO

IL LETTO A CASTELLO CON ARMADIO
È UNA SOLUZIONE INTELLIGENTE
PER SFRUTTARE AL MEGLIO LO SPAZIO
IL LETTO SUPERIORE PUÒ ESSERE
FACILMENTE RIASSETTATO GRAZIE AL
MECCANISMO DI RIORDINO

Priceless space
The bunk bed with the wardrobe is an intelligent solution, taking full advantage of your space. What's more - the upper bed can be easily made up thanks to the "rearrange" mechanism

L'espace est précieux
Les lits superposés avec armoire représentent une solution intelligente pour exploiter au mieux l'espace. Le lit supérieur peut être facilement refait grâce au mécanisme de rangement

Raum ist kostbar
Etagenbetten mit Schrank sind die intelligente Lösung, um Raum zu gewinnen. Durch einen spezifischen Mechanismus kann das obere Bett leicht gemacht und bezogen werden.







RIGOROSITÀ E VERSATILITÀ IN UNA COMBINAZIONE PERFETTA UNA NUOVA ED ORIGINALE PROPOSTA PER RIVISITARE L'IDEA DI COMODINO LE LIBRERIE MULTIBOX SONO VERSATILI ED ADATTE AD INTERPRETARE LE MOLTEPLICI ESIGENZE DELLO SPAZIO GIOVANI

Thorough and versatile design - the perfect combination
A new, truly original offer that reinvents your concept of the bedside table.
The Multibox bookshelves are versatile and simply perfect for interpreting your kids' numerous needs

Rigueur et polyvalence: une parfaite combinaison
Une nouvelle proposition originale pour repenser l'idée de table de chevet. Les bibliothèques Multibox sont polyvalentes et adaptées à interpréter les multiples exigences de l'espace des jeunes

Perfekte Kombinationen dank Vielseitigkeit und formaler Strenge
Eine neue und originelle Variation zum Thema des Nachttischs. Multibox-Bücherregale sind vielseitig, um dem unterschiedlichen Raumbedarf junger Leute Rechnung zu tragen







UNO SCRITTOIO DOPPIO SPAZIO

LO SCRITTOIO SU RUOTE
È ESTRAIBILE E RUOTABILE
E PUÒ ESSERE UTILIZZATO
COME UN SECONDO ED
AUTONOMO SPAZIO DI LAVORO

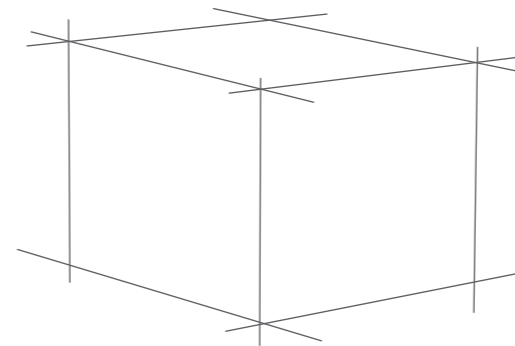

A desk and double the space
The rolling desk can be pulled out and
wheeled around, or even used as a
second, independent workspace

Un bureau: un espace redoublé
Le bureau sur roulettes est extractible et
pivotant et peut-être utilisé comme un
deuxième espace de travail autonome

Ein Schreibtisch, doppelte Arbeitsfläche
Der Schreibtisch ist fahrbar und kann
herausgefahren werden, um eine zweite
Arbeitsfläche zu bieten

FINO A 3,5 M DI LUNGHEZZA

LA STRUTTURA PONTE SI PUÒ ESTENDERE FINO AD ACCOGLIERE SIA IL LETTO CHE LO SCRITTOIO ED È SOSTENUTA DA UN ROBUSTO TELAIO NEL QUALE È POSSIBILE INSTALLARE DELLE LAMPADE

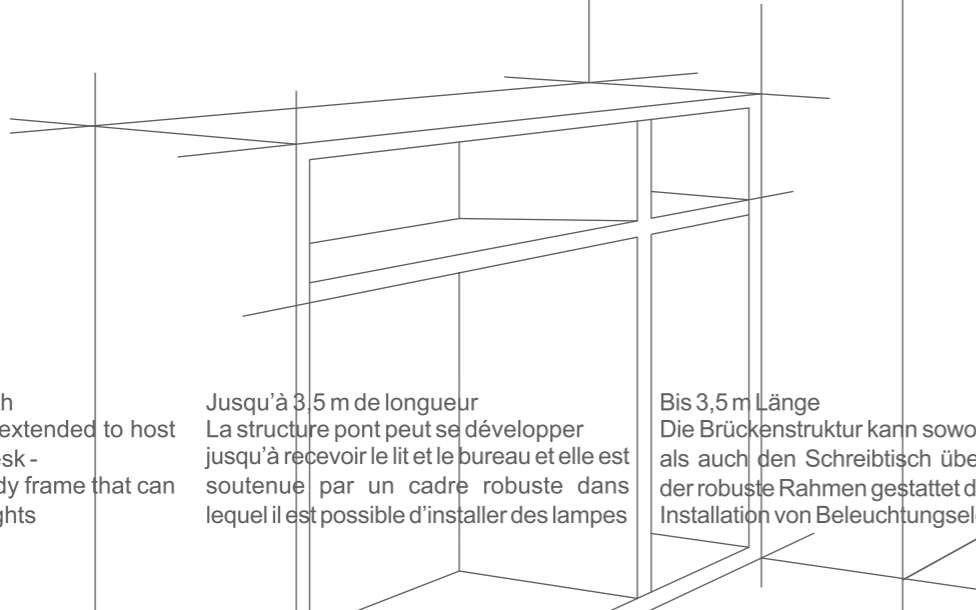

Up to 3.5 meters in length
The bridge unit can be extended to host the bed as well as the desk - it is supported by a sturdy frame that can also be equipped with lights

Jusqu'à 3,5 m de longueur
La structure pont peut se développer jusqu'à recevoir le lit et le bureau et elle est soutenue par un cadre robuste dans lequel il est possible d'installer des lampes

Bis 3,5 m Länge
Die Brückenstruktur kann sowohl das Bett als auch den Schreibtisch überspannen; der robuste Rahmen gestattet die Installation von Beleuchtungselementen





*"The alarm rings and a new day begins.
Breakfast and then off to school.
A long day awaits and you need all the energy you can get.
Lunch and then it's time to hit the books.
But you also need a break once in a while - a little bit of TV and some
ruckus with friends, and then back to studying.
The evening sets in and the room is a mess: books, pictures, CDs,
clothes everywhere, a tablet, the console...
...and if someone walked in right now!
A kid's life really isn't that simple.
Thankfully there's Multibox, and everything falls right into place!"*

*"Le réveil sonne et une nouvelle journée commence.
Un petit-déjeuner et ensuite vite à l'école.
La journée est longue et nécessite un plein d'énergie.
Déjeuner et se mettre à étudier tout de suite après.
Mais de temps en temps il faut faire un break: juste un peu de télé
et un peu de chahut entre amis puis se remettre à étudier.
Le soir arrive et le désordre règne dans la chambre:
livres, photographies, CD, des vêtements par ci par là, la tablette, la console...
...si quelqu'un arrivait à ce moment-là!
La vie de jeunes adolescents n'est pas simple.
Heureusement il y a Multibox et
en un instant tout est rangé!"*

*"Der Wecker klingelt und ein neuer Tag beginnt.
Nach dem Frühstück geht es ab in die Schule.
Der Tag ist lang und verschlingt viel Energie.
Gleich nach dem Mittagessen wird gelernt.
Aber ab und zu darf man sich eine Spiel- oder Fernseh-Pause mit
Freunden gönnen, bevor man sich wieder an Hefte und Bücher setzt.
Am Abend herrscht dann das reine Chaos: Bücher, CDs, Fotos,
Kleidungsstücke, die Konsole und das Tablet sind im Raum verstreut...
...wenn jetzt bloß keiner reinkommt!
Als Kind lebt es sich auch nicht so einfach.
Zum Glück gibt es Multibox und im Nu ist alles wieder aufgeräumt!"*

*“ Suona la sveglia ed inizia un nuovo giorno.
Colazione e poi di corsa a scuola.
La giornata è lunga e ci vogliono tante energie.
Pranzo e poi subito a studiare.
Ma ogni tanto ci vuole un break: giusto un po' di TV
e un po' di caos con gli amici
poi di nuovo sui libri.
Arriva sera ed il disordine regna nella camera:
libri, fotografie, CD, vestiti qua e là, il tablet, la console...
...se arrivasse qualcuno in questo momento!
La vita da ragazzi non è poi così semplice.
Per fortuna esiste Multibox ed
in un attimo tutto è al suo posto! ”*



Multibox è una collezione di contenitori che si
Multibox is a collection of storage boxes that adapt to meet

adattano a qualsiasi esigenza dello spazio ra-
the kids' each and every need. Hanging units, bases, or even

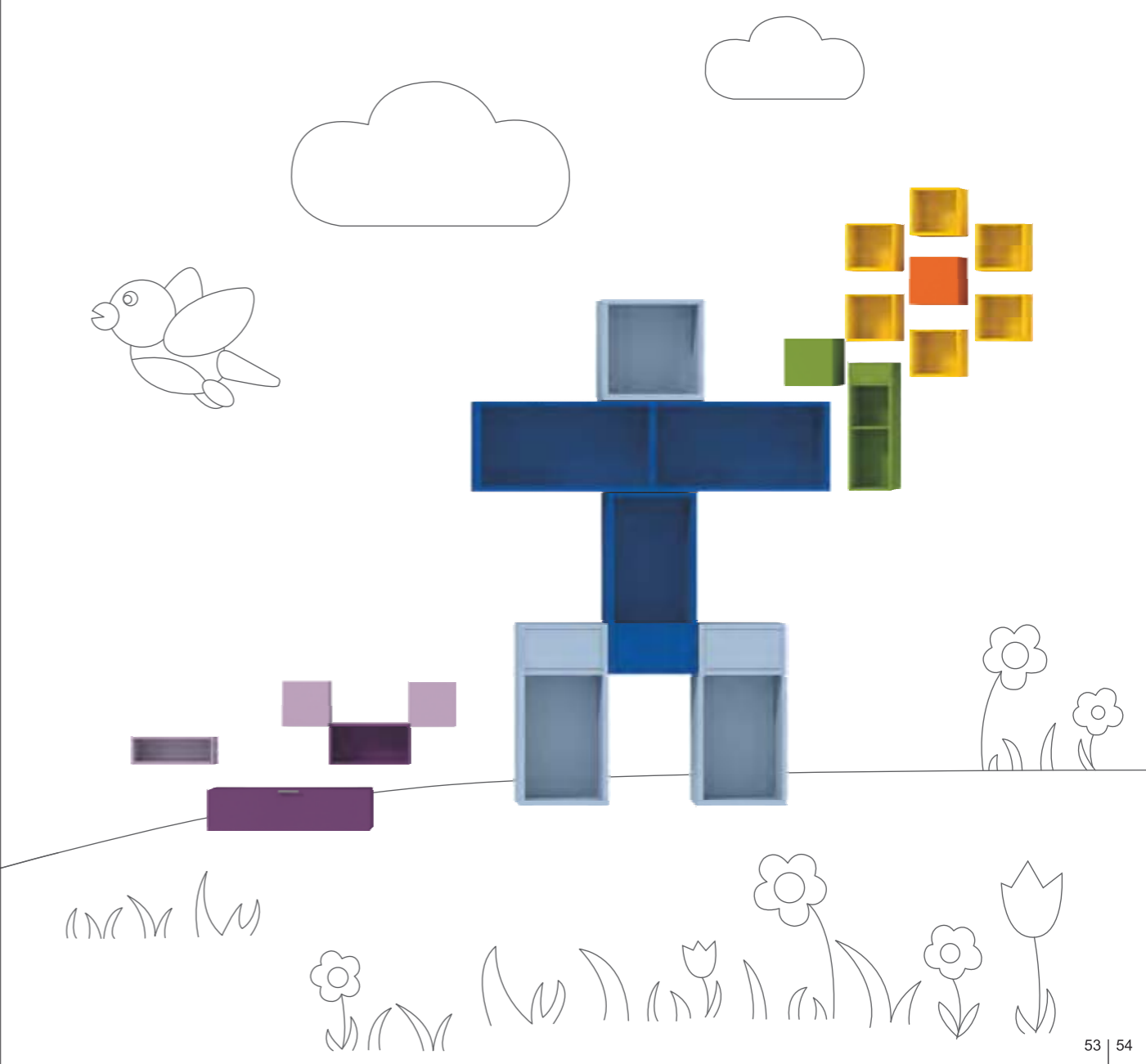

gazzi. Pensili, basi o su ruote. Ante, cassetti e
on wheels. Doors, drawers and chests. An infinite number

cestoni. Infinite combinazioni per accontenta-
of combinations - satisfying everyone. Multibox for playing

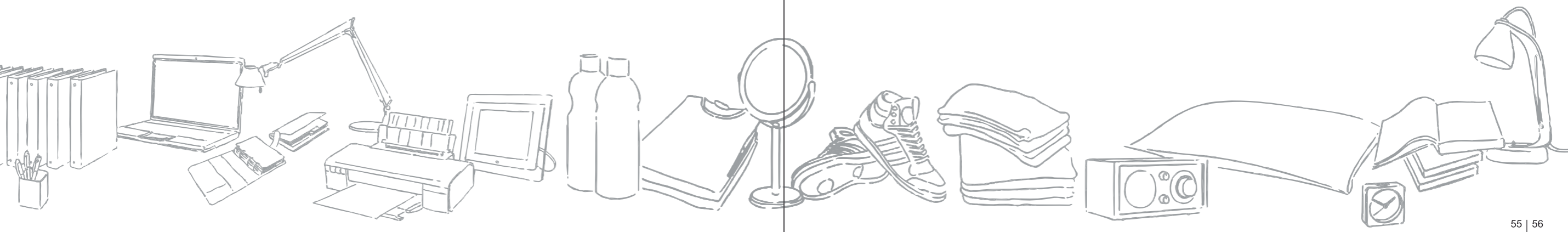

re tutti. Multibox per giocare, studiare o lavorare.
studying and working. Discover the entire collection at your

Scopri l'intera collezione presso i rivenditori!
nearest retailer!

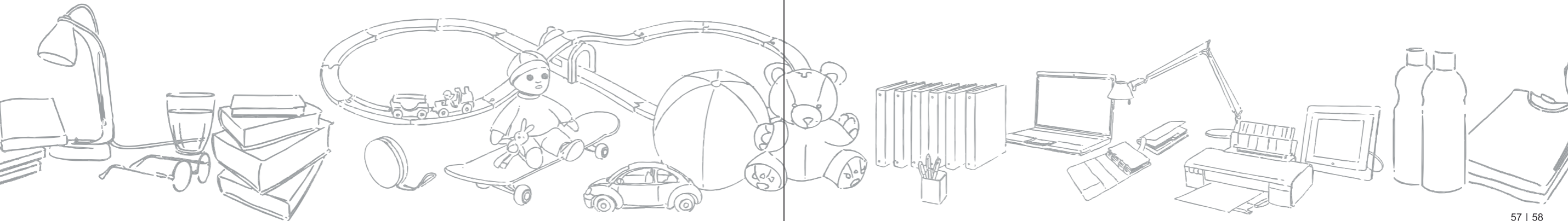
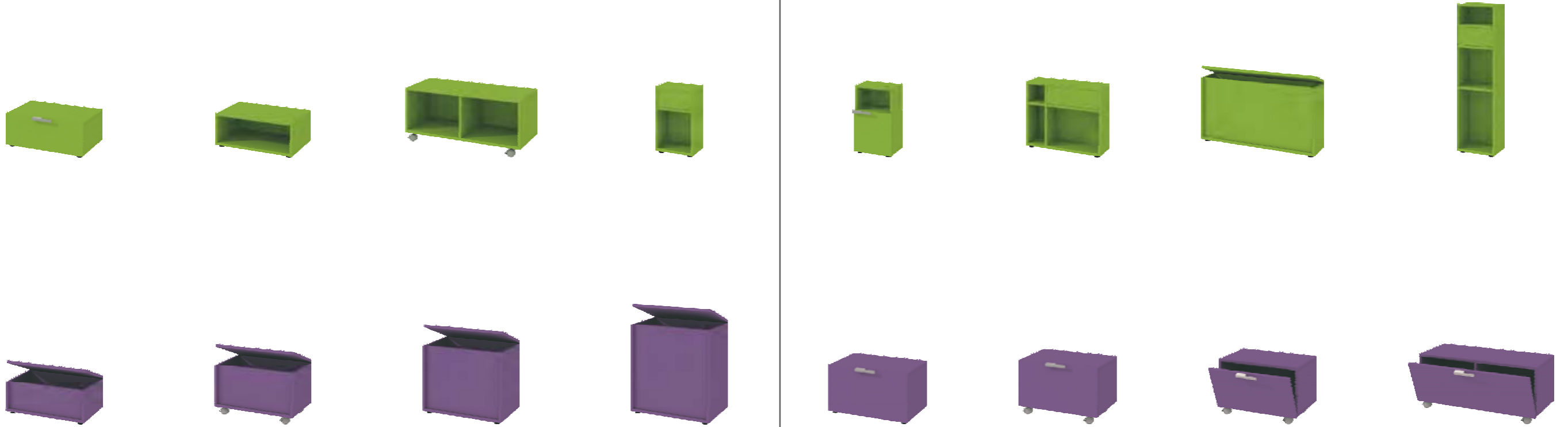

Nella collezione Freestyle sono disponibili armadi, letti singoli ed a castello, scrittoi, librerie, boiserie, mensole e tanti altri accessori che permettono di progettare lo spazio ragazzi in modo originale e funzionale

The Freestyle collection offers wardrobes, single and bunk beds, desks, bookshelves, wainscoting, shelves, and numerous other accessories that will make it easy to design the kids' room in an original and practical way

La collection est composée d'armoires, de lits à une place et superposés, de bureaux, de bibliothèques, de boiseries, de consoles et beaucoup d'autres accessoires qui permettent de projeter l'espace des jeunes adolescents de façon originale et fonctionnelle

In der Kollektion Freestyle stehen Schränke, Einzel- und Etagenbetten, Bücherregale, Wandverkleidungen und Ablagen zur Verfügung - mit vielseitigem Zubehör, um das Kinderzimmer so originell und funktionell wie möglich zu gestalten

MANUALE TECNICO

TECHNICAL MANUAL

MANUEL TECHNIQUE

TECHNISCHES HANDBUCH

Sistema armadi

Wardrobes system | Système armoires | Systemschränke

Letti singoli

Single beds | Lits à une place | Einzelbetten

Letti a castello

Bunk beds | Lits superposés | Etagenbetten

Letti 1x2

1x2 Beds | Lits 1x2 | 1x2 Betten

Scrittoi

Writing desks | Bureaux | Schreibtische



Sistema armadi

Wardrobes system | Système armoires | Systemschränke

Un sistema di contenitori versatile, composto da molteplici soluzioni ed innumerevoli moduli adattabili alle esigenze di ogni singolo cliente per realizzare armadi personalizzati sia nelle misure che nelle finiture.

A system of versatile storage units, made up of numerous solutions and countless modules that will meet the client's each and every need - creating customised wardrobes based on measurements, size, and finishes.

Un système polyvalent d'éléments, composé de multiples solutions et d'innombrables modules adaptables aux exigences de chaque client pour réaliser des armoires personnalisées en termes de mesures et de finitions.

Vielseitiges System für die individuelle Gestaltung von Gesamtlösungen, die in Abmessungen, Farben und Materialien auf die Anforderungen des einzelnen Kunden zugeschnitten sind.

Armadi ante battenti

Wardrobes with leaf doors | Armoires avec portes battantes | Schränke mit Flügeltüren

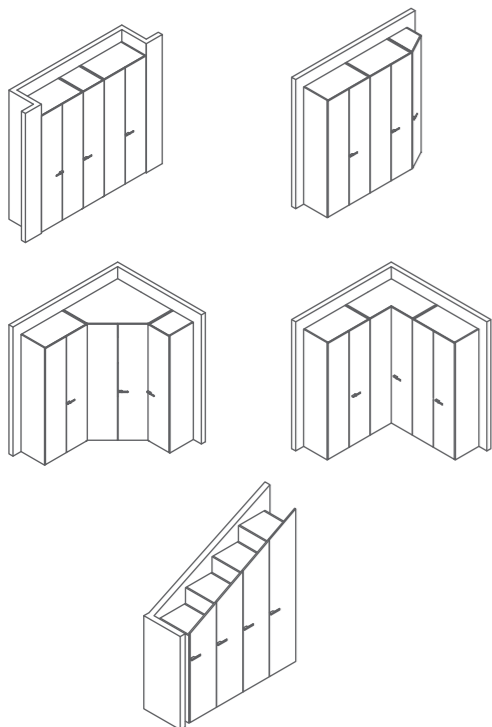

Il sistema di armadi ad ante battenti vanta una modularità molto evoluta che ne consente l'inserimento in ogni spazio. Grazie ad alcuni elementi "speciali" (armadi angolari e terminali) è possibile risolvere le differenti esigenze di arredo.

Il sistema dispone di un'ampia varietà di modelli, con ante, cassetti, cestoni e vani a giorno, liberamente combinabili tra di loro.

È inoltre possibile realizzare soluzioni ad hoc per ambienti mansardati.

This system for wardrobes with leaf doors offers cutting-edge modularity that makes it perfect for any and every interior. Thanks to some "special" elements (corner and end units), you can satisfy even the toughest furnishing needs.

This system also has a vast array of models, doors, drawers, chests, and open units, all which you can pair up in absolute freedom.

Moreover, this system also offers solutions for attics and mansards.

Le système d'armoires à portes battantes vante une modularité très évoluée qui permet son insertion dans tout espace. Grâce à quelques éléments "spéciaux" (armoires d'angle et d'extrémité) il est possible de résoudre toute exigence d'ameublement.

Le système dispose d'une vaste variété de modèles, avec portes, tiroirs, grands paniers et compartiments ouverts, librement associables entre eux.

Il est en outre possible de réaliser des solutions spéciales pour des zones mansardées.

Dank hoher Modularität passt dieses Schranksystem mit Flügeltüren in jeden Raum. Mit "Spezialelementen" (darunter Eckschränke und Endstücke) kann jeder Raum zweckmäßig eingerichtet werden.

Das System bietet ein breit gefächertes Angebot an Modellen und frei kombinierbaren Flügeltüren, Schubladen, Körben und offenen Regalfächern.

Für Mansarden können Ad-hoc-Lösungen erstellt werden.

Armadi anta battente e scorrevole

Wardrobes leaf/sliding door | Armoires porte battante/coulissante | Schränke mit Flügel- und Schiebetür

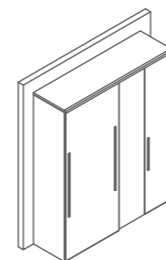

Il sistema misto anta scorrevole ed anta battente presenta un grande vantaggio: il modulo con anta scorrevole può essere realizzato senza base. Questo ne consente l'inserimento di contenitori o scrittoi su ruote.

This mixed system for wardrobes with sliding and leaf doors offers an enormous advantage: the module with the sliding door can be built without the base. This allows for the practical addition of rolling storage units and writing desks.

Le système mixte porte coulissante et porte battante présente un grand avantage: le module avec porte coulissante peut être réalisé sans base. Ce qui permet l'insertion d'éléments ou de bureaux sur roulettes.

Das Kombi-Schranksystem mit Flügel- und Schiebetüren bietet einen großen Vorteil: das Element mit Schiebetür benötigt keinen Einlegeboden und kann daher rollbare Behälter und Schreibtische aufnehmen.

Armadi scorrevoli

Wardrobes with sliding doors | Armoires avec portes coulissantes | Schränke mit Schiebetüren

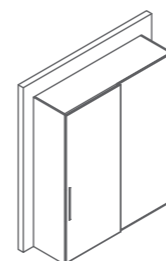

Il sistema di armadi ad ante scorrevoli è la soluzione ideale in spazi ristretti grazie all'ingombro minimo delle ante.

Disponibili soluzioni con due, tre e quattro ante scorrevoli.

The system for wardrobes with sliding doors is the ideal solution for those with little room to spare, thanks to the minimum amount of space these doors occupy. These wardrobes are available in two, three, and four door solutions.

Le système d'armoires avec portes coulissantes est la solution idéale dans des espaces réduits grâce à l'encombrement minimum des portes. Solutions disponibles avec deux, trois et quatre portes coulissantes.

Dank ihres minimalen Raumbedarfs sind Schrankssysteme mit Schiebetüren die ideale Lösung bei Platzmangel.

Es stehen Lösungen mit zwei, drei und vier Schiebetüren zur Auswahl.

Strutture ponte

Bridge units | Structures pont | Brückenstrukturen

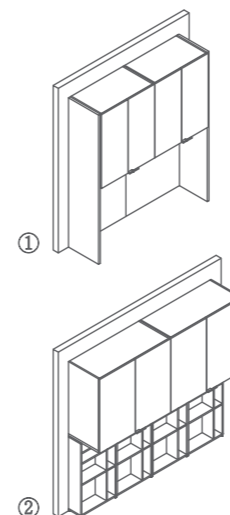

Nel sistema armadi sono presenti due soluzioni per la realizzazione di armadi ponte: struttura ponte con telaio ① e struttura ponte con Multibox ②.

La soluzione ① si può estendere fino a 3,5 m ed è sostenuta ai lati da fianchi o da armadi. La soluzione ② non ha limiti di estensione in lunghezza ed utilizza come sostegno le librerie Multibox.

The system offers two solutions for bridge wardrobes: ① with frame and bridge unit with Multibox ②. This solution ① can reach up to 3.5 meters and is supported on the sides by lateral units or wardrobes. This solution ② has no limits in length and uses the Multibox bookshelves as support.

Dans le système armoires sont présentes deux solutions pour la réalisation d'armoires pont: structure pont avec cadre ① et structure pont avec Multibox ②. La solution ① peut atteindre 3,5 m et est soutenue aux extrémités par des côtés ou par des armoires. La solution ② n'a pas de limites d'extension en longueur et utilise comme soutien des bibliothèques Multibox.

Im Schranksystem stehen zwei Lösungen für die Realisierung einer Schrankbrücke zur Auswahl: Brückenstruktur mit Rahmen ① und Brückenstruktur mit Multibox ②.

Die Lösung ① kann bis zu 3,5 m lang sein und auf Seitenelementen oder Schränken aufliegen. Die Lösung ② hat keine Längenbeschränkung; als Stützelemente fungierten Multibox-Regale.



C'è più colore in tutto quel che fai!

Make everything you do more colourful! | Toujours plus de couleur!



Uno dei plus della collezione Freestyle è la sua estrema flessibilità, sia in termini di misure che di finiture. Grazie ad un innovativo sistema di produzione siamo in grado di offrire la personalizzazione di ognuno dei 6500 articoli della collezione senza nessun limite.

Persino l'interno del vostro armadio sarà personalizzabile scegliendo tra le finiture proposte nella nostra gamma. Una grande possibilità per creare combinazioni uniche.



| Hol dir mehr Farbe in dein Leben!

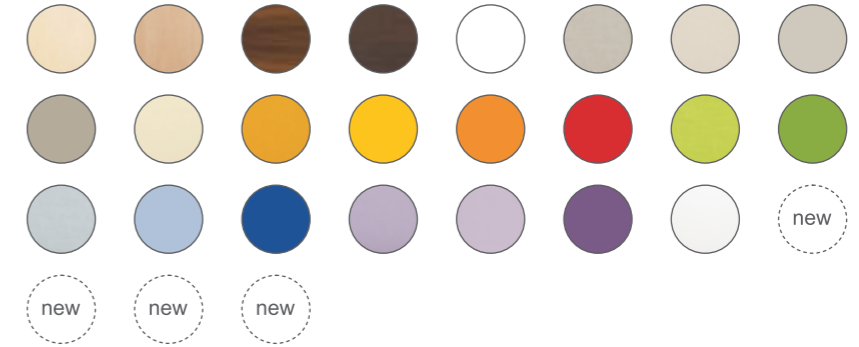
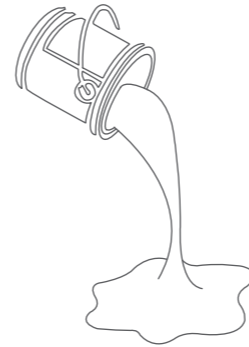

An extra from the Freestyle collection is its utmost flexibility, regarding measurements and size, as well as finishes. Thanks to our innovative production system, we are able to personalise and customise each and every one of our 6500 articles from this collection, without any limitations. Even the interior of the wardrobes and closets can be customised with your choice of finishing from our vast selection - a great chance to create one-of-a-kind combinations.

Un des plus de la collection Freestyle est son extrême flexibilité, en termes de mesures et de finitions. Grâce à un système innovateur de production nous sommes en mesure de personnaliser chacun des 6500 articles de la collection sans aucune limite. Même la partie interne de votre armoire pourra être personnalisée en choisissant parmi les finitions proposées à l'intérieur de notre gamme. Une grande possibilité de créer des combinaisons uniques.

Die extreme Flexibilität bei Abmessungen und Fertigbearbeitungen ist einer der wichtigen Pluspunkte der Kollektion Freestyle. Dank unseres innovativen Produktionssystems können wir alle 6500 Artikel der Kollektion ausnahmslos auf individuelle Wünsche abstimmen. Sogar das Schrankinnere kann durch die Auswahl aus unseren Verarbeitungsoptionen personalisiert werden. Eine große Chance, einzigartige Kombinationen zu erstellen.





Letti singoli

Single beds | Lits à une place | Einzelbetten



Finiture
Finishing
Finitions
Fertigbearbeitungen

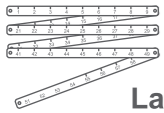

Larghezza
Widths
Largeurs
Breiten

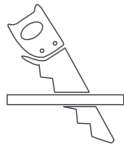

su Misura
Custom-made
Sur-mesure
Maßgeschneidert



Personalizzazione
Customization
Personnalisation
Personalisierung



Colori

Colours | Couleurs | Farben

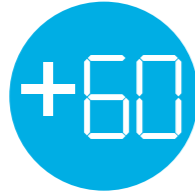

Tessuti

Fabrics | Tissus | Stoff

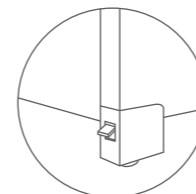
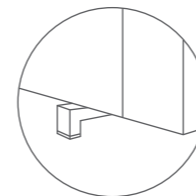
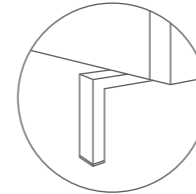
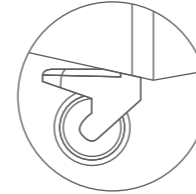
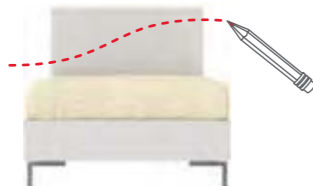
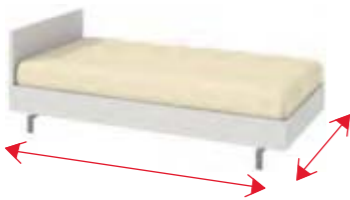
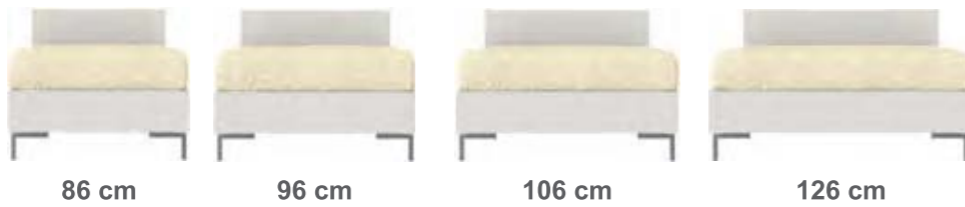

Le nostre collezioni:

Our collections:

Nos collections:

Unsere Kollektionen:

system **FH28**

system **FH28 BIG**

system **FH19**

system **FH10**



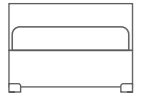

System FH28

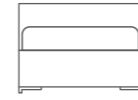
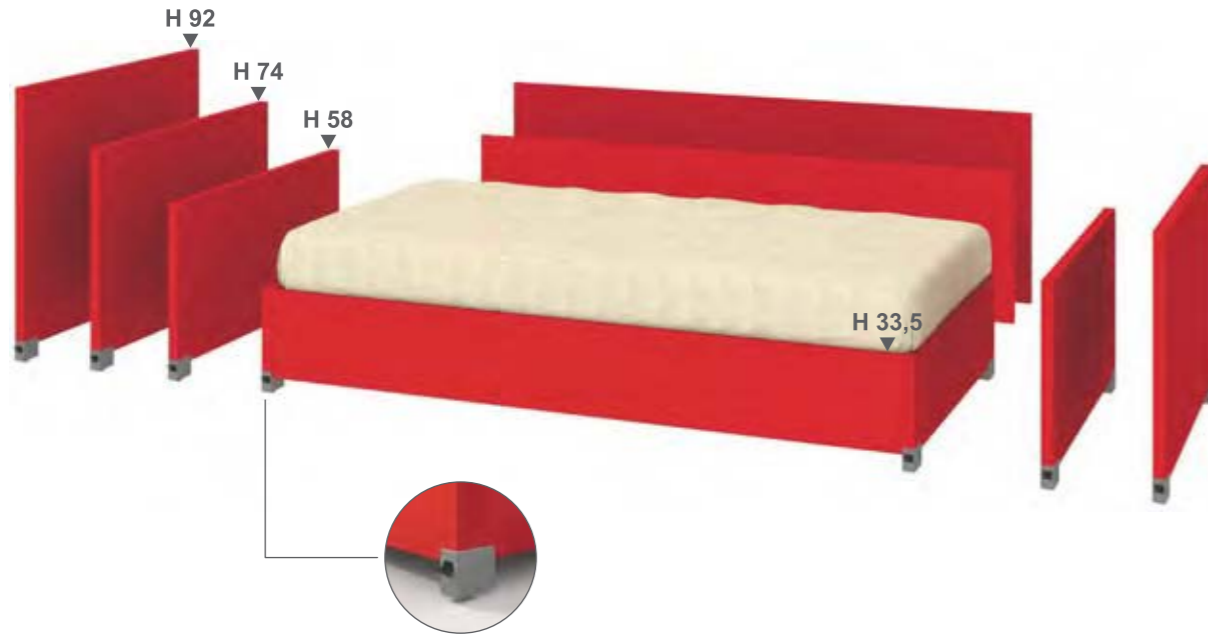

System FH28 BIG

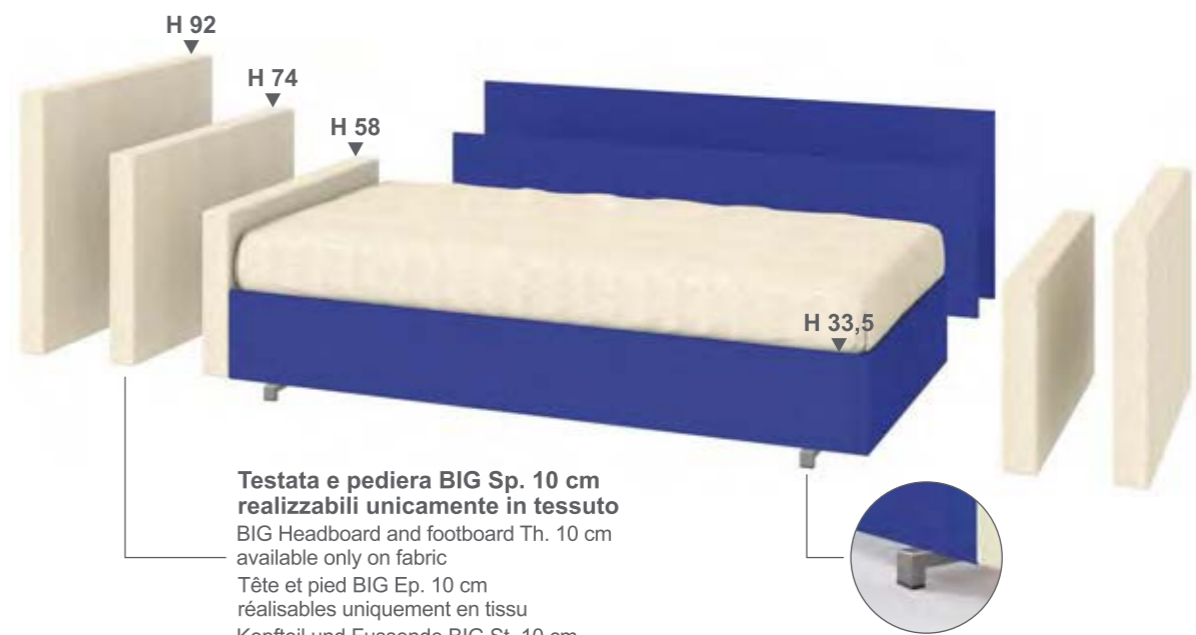

Testata e pediera BIG Sp. 10 cm realizzabili unicamente in tessuto
BIG Headboard and footboard Th. 10 cm available only on fabric
Tête et pied BIG Ep. 10 cm réalisables uniquement en tissu
Kopfteil und Fussende BIG St. 10 cm nur aus Stoff realisierbar

Tipologie

Typologies
Typologies
Typologien

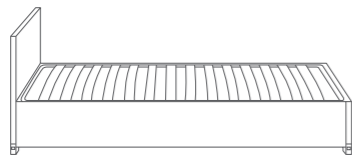

Rete fissa
Fixed slats
Sommier fixe
Fixlattenrost

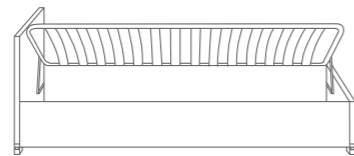

Letto con contenitore
Bed with storage base
Lit avec rangement
Bett mit Kasten

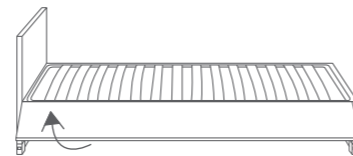

*** Letto con fascia apribile**
Bed with liftable frame
Lit avec bande ouvrante
Bett mit aufklappbarer Leiste

Tipologie

Typologies
Typologies
Typologien

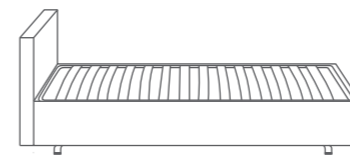

Rete fissa
Fixed slats
Sommier fixe
Fixlattenrost

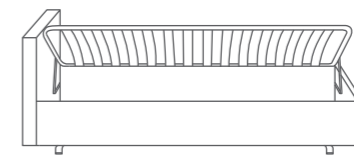

Letto con contenitore
Bed with storage base
Lit avec rangement
Bett mit Kasten

* Accessori

Accessories
Accessoires
Zubehör



*** Cassettoni su ruote**
Big drawers on wheels
Grands tiroirs sur roulettes
Schubladen auf Rollen

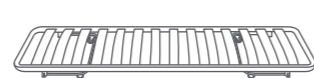

*** Rete estraibile**
Pull-out slats
Sommier extractible
Ausziehbarer Lattenrost



*** Rete estraibile con testata**
Pull-out slats with headboard
Sommier extractible avec tête
Ausziehbarer Lattenrost mit Kopfteil



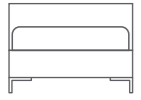

System FH19

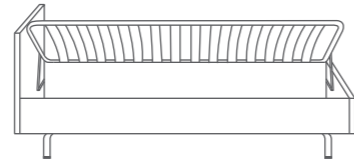
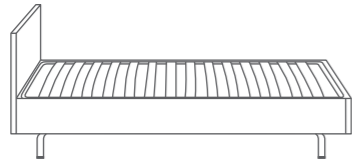

Tipologie
Typologies
Typologies
Typologien

Rete fissa
Fixed slats
Sommier fixe
Fixlattenrost

Letto con contenitore
Bed with storage base
Lit avec rangement
Bett mit Kasten

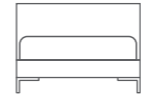

System FH10

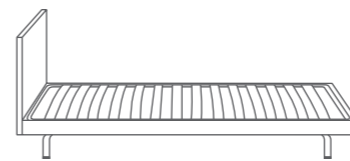

Tipologie
Typologies
Typologies
Typologien

Rete fissa
Fixed slats
Sommier fixe
Fixlattenrost





Letti a castello

Bunk beds | Lits superposés | Etagenbetten



Finiture

Finishing
Finitions

Fertigbearbeitungen



Colori

Colours | Couleurs | Farben



Sistemi di salita

Ladders and stairs
Echelles et escaliers

Treppen / Leitersysteme

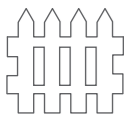

Protezioni

Protection bars
Protections

Schutzvorrichtungen



Accessori

Accessories
Accessoires

Zubehör



Meccanismo per riordino del letto

System for the tiding up of bed
Mécanisme pour le rangement du lit
Mechanismus zum Bettenmachen



su Misura

Custom-made
Sur-mesure

Maßgeschneidert

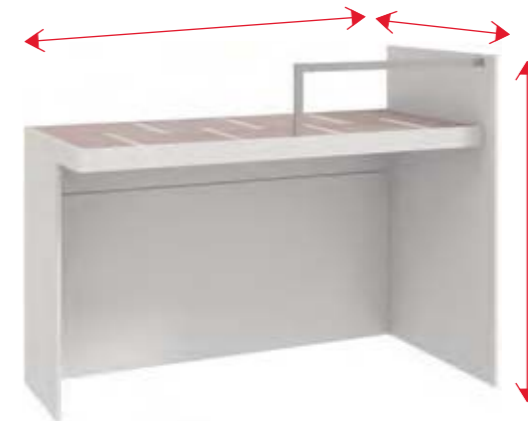



Sistemi di salita

Ladders and stairs | Echelles et escaliers | Treppen / Leitersysteme



Scala a pioli da riporre nell'apposito contenitore.
Rung ladder that fits in side storage unit.
Echelle à placer dans le logement prévu.
Leiter mit Unterbringung in speziellem Stauraum.



Salita da posizionare a lato del letto.
Possibilità di aggiunta di cassetti.
Stair placed next to bed. Drawers can be added.
Escalier à placer le long du lit. Possibilité d'ajouter des tiroirs.
Seitlich am Bett angeordnete Treppe.
Möglichkeit zusätzlicher Schubladen.



Salita da posizionare lungo il letto, dotata di mensola e contenitore.
Possibilità di aggiunta di cassetti.
Stair that fits alongside the bed, equipped with shelf and storage unit. Drawers can be added.
Escalier à placer le long du lit avec étagère et élément.
Possibilité d'ajouter des tiroirs.
Treppe wird seitlich am Bett angeordnet und stellt einige Staufächer zur Verfügung. Möglichkeit zusätzlicher Schubladen.

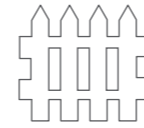

Protezioni

Protection bars | Protections | Schutzvorrichtungen



*** Protezione con rivestimento in tessuto**
Protection bar covered with fabric
Protection avec revêtement en tissu
Schutzstange mit Stoffverkleidung





Proposte

Proposals | Propositions | Vorschläge

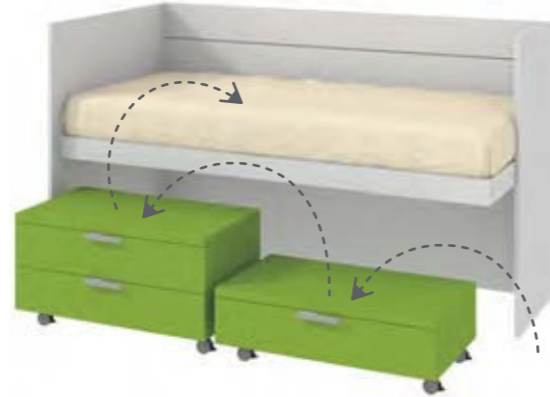

LETTI
1x2

Letti 1x2

1x2 Beds | Lits 1x2 | Betten 1x2



Finiture

Finishing
Finitions

Fertigbearbeitungen



Colori

Colours | Couleurs | Farben



2 letti nello spazio di 1

2 beds in the space of one
2 lits à la place d'un
2 Betten auf dem Platz von 1



Disponibile in oversize fino ad una piazza e mezza

Available in oversize, up to the size of a queen bed
Disponibile en oversize jusqu'à une place et demie
Auch in Übergröße als französisches Bett verfügbar



Rifacimento semplice

Easy rearranging
Facile à faire
Bettenbeziehen leicht gemacht



Sacca portaoggetti in tessuto

Fabric storage unit
Poche porte-objets en tissu
Stofftaschen zum Verstauen von Gegenständen



Plus

Plus
Plus
Plus



Accessori

Accessories
Accessoires
Zubehör



Posizione scala

Positioning of the ladder
Position de l'échelle
Leiterpositionierung

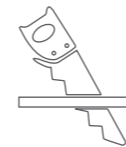

su Misura

Custom-made
Sur-mesure
Maßgeschneidert





Letti 1x2 con piedi o con ruote

1x2 with feet/wheels | 1x2 avec pieds/roulettes | 1x2 mit Füßen/Rollen



Larghezza
Widths
Largeurs
Breiten

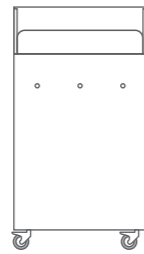

86 cm

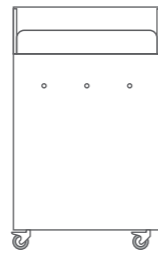

96 cm

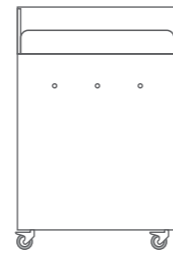

106 cm

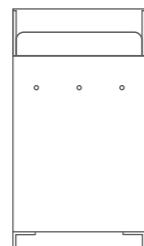

86 cm

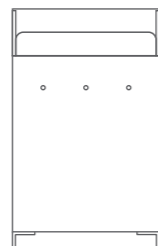

96 cm

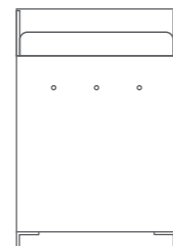

106 cm

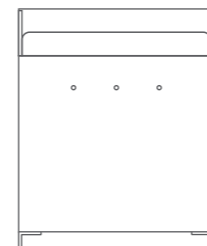

126 cm



Letti 1x2 con fascia apribile

1x2 liftable frame | 1x2 bande ouvrante | 1x2, aufklappbare Leiste



Larghezza
Widths
Largeurs
Breiten

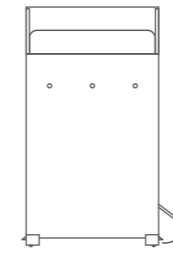

86 cm

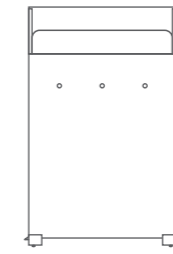

96 cm

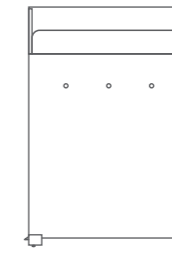

106 cm

Accessori
Accessories
Accessoires
Zubehör



Cassettini su ruote
Big drawers on wheels
Grands tiroirs sur roulettes
Schubladen auf Rollen

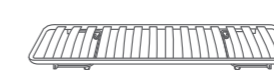

Rete estraibile
Pull-out slats
Sommier extractible
Ausziehbarer Lattenrost



Rete estraibile con testata
Pull-out slats with headboard
Sommier extractible avec tête
Ausziehbarer Lattenrost mit Kopfteil





Scrivani

Writing desks | Bureaux | Schreibtische



Finiture

Finishing
Finitions

Fertigbearbeitungen



Colori

Colours | Couleurs | Farben



Piano scrivano

Writing top | Plan bureau | Schreibtischplatte



su Misura

Custom-made
Sur-mesure
Maßgeschneidert



Personalizzazione

Customization
Personnalisation
Personalisierung

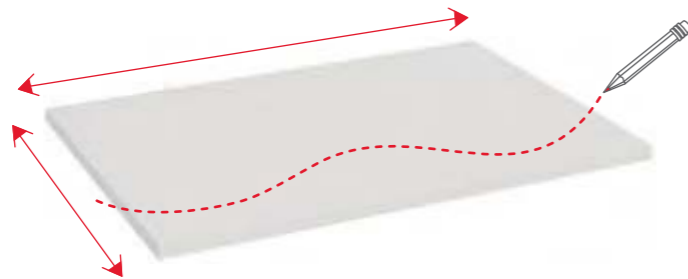

Supporti

Supports | Soutiens | Stützen

Gambe

Legs
Pieds
Beine



Gamba fissa o con ruota

Set leg or with wheel
Pied fixe ou avec roulette
Rollbares oder festes Tischbein



Gamba regolabile

Adjustable leg
Pied réglable
Höhenverstellbares Tischbein

Strutture

Frames
Structures
Rahmen



Moduli

Units
Modules
Elemente



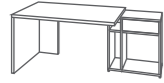

Proposte

Proposals | Propositions | Vorschläge



Scrittoi con struttura in metallo

Il piano scrittoio può essere realizzato al cm estendendosi oltre la struttura

Metal frame writing desk. The desktop can be manufactured based on size requests, extending beyond the frame

Bureaux avec structure en métal. Le plan bureau peut être réalisé au cm en s'étendant outre la structure

Schreibtische mit Metallstruktur. Die Abmessungen der Tischplatte können auf den Zentimeter genau angefertigt werden und länger als die Struktur sein



Scrittoio con doppio piano girevole

Il piano inferiore è estraibile e ruotabile in tutte le direzioni

Writing desk with rotating double top. The lower top can be extracted and rotated in all directions

Bureau avec double plan tournant. Le plan inférieur est extractible et pivotant dans toutes les directions

Schreibtisch mit doppelter drehbarer Tischplatte. Die untere Platte ist herausziehbar und kann in alle Richtungen gedreht werden



Scrittoi con doppio piano indipendente su ruote

Lo scrittoio su ruote è una superficie di lavoro che può essere ordinatamente riposta sotto lo scrittoio fisso

Writing desk with independent double top on wheels. This writing desk on wheels is a worktop that can be placed underneath the fixed desk when you need to tidy up

Bureaux avec double plan indépendant sur roulettes. Le bureau sur roulettes est un plan de travail qui peut être rangé sous le bureau fixe

Schreibtische mit doppelter Arbeitsfläche auf Rollen: mehr Ordnung durch einen Schreibtisch auf Rollen. Bei Bedarf kann diese zweite Arbeitsfläche wieder unter den fixen Schreibtisch geschoben werden



Scrittoi con Multibox

Le possibilità di realizzazione di scrittoi con Multibox sono infinite e personalizzabili a seconda delle esigenze

Writing desks with Multibox. You can create writing desks with Multibox – infinite and customizable options, based on your each and every need

Bureaux avec Multibox. Les possibilités de réalisation de bureaux avec Multibox sont infinies et personnalisables selon les exigences

Schreibtische mit Multibox. Multibox bietet für alle Anforderungen an einen Schreibtisch die Möglichkeit einer maßgeschneiderten Lösung



Concept & Graphic Design
DASudio by Erba

Print 03.2014

ERBA s.r.l.

Via don Guanella, 28 - c.p. 119
22066 Mariano Comense (Como)
T +39 031 746 663
F +39 031 750 624
www.erbamobili.it
erba@erbamobili.it

